

# VI Chip® PRM™ Evaluation Board



Contents	Page
<a href="#">Introduction</a>	1
<a href="#">Features</a>	3
<a href="#">Board Description</a>	4
<a href="#">General Components</a>	5
<a href="#">Test Points Description</a>	7
<a href="#">Sockets Description</a>	8
<a href="#">Schematic</a>	9
<a href="#">Assembly Drawings</a>	11
<a href="#">Bill of Materials</a>	13
<a href="#">VTM™ Evaluation Boards</a>	16
<a href="#">Recommended</a>	
<a href="#">Test Equipment</a>	17
<a href="#">Push-Pin</a>	
<a href="#">Heat Sink Installation</a>	17
<a href="#">Line and Load</a>	
<a href="#">Connections</a>	18
<a href="#">Board Operating Modes</a>	18
<a href="#">Default / Adaptive-Loop</a>	
<a href="#">Operating Mode</a>	
<a href="#">Using PRM™</a>	20
<a href="#">Adaptive-Loop Operating Mode</a>	
<a href="#">Using PRM™ and VTM™21</a>	21
<a href="#">Remote-Sense Operating Mode</a>	
<a href="#">Using PRM: Local Sensing</a>	
<a href="#">(Single Ended)</a>	21
<a href="#">Remote-Sense Operating Mode</a>	
<a href="#">Using PRM™ and VTM™:</a>	
<a href="#">Non-Isolated Remote</a>	
<a href="#">Sensing (Differential</a>	
<a href="#">Sensing)</a>	23
<a href="#">Child Operating</a>	
<a href="#">Mode (Arrays)</a>	26
<a href="#">Paralleling</a>	26
<a href="#">Conclusion</a>	27

## Introduction

The PRM™ evaluation boards described in this document are designed to use with the PRM family of PRM regulators and demonstrate the benefits of the Factorized Power Architecture™. These evaluation boards are not designed for installation in end-user equipment. The system demonstrates the use of a PRM (the pre-regulator module) and a VTM (the current multiplier or the voltage transformation module) for general laboratory evaluation only.

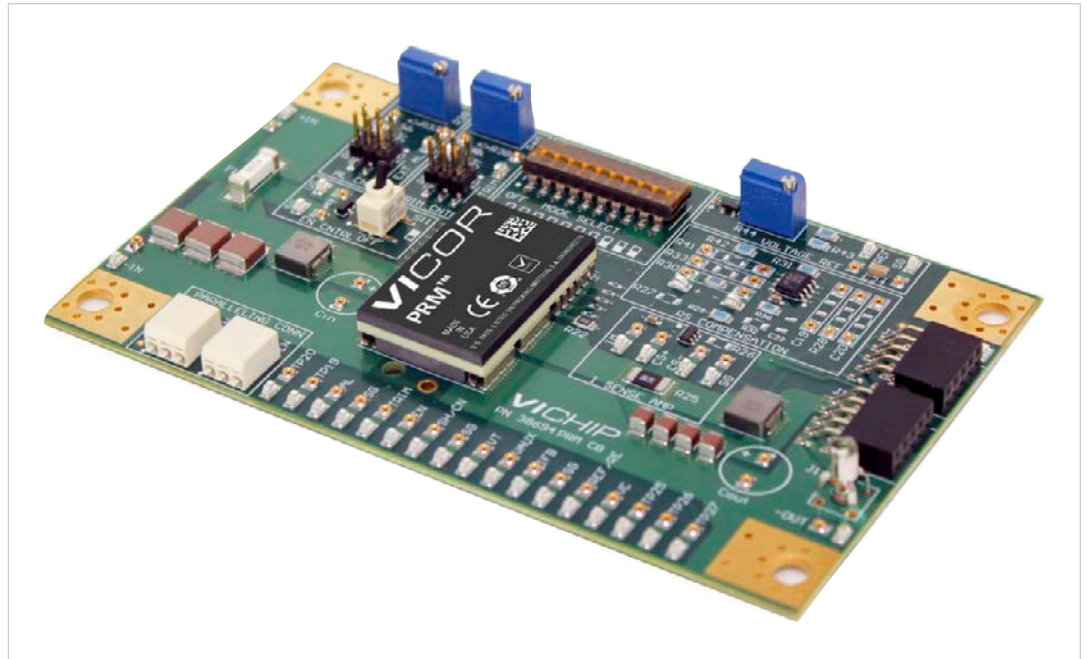

### IMPORTANT NOTICE:

Be sure to read this design guide manual thoroughly before using this product. Pay attention to all cautions and warnings.

This user guide is not comprehensive and is not substitute for common sense and good practice. For example:

- When testing electronic product always use approved safety glasses.
- Provide a strain relief for wires and place the system on the bench in such a way as to prevent accidental displacement from bench top.
- Remove the power and use caution when connecting and disconnecting test probes and interface lines to avoid unintentional short circuits and contact with hot surfaces.
- Never use a jumper in place of the fuse. Replace the fuse only with its equivalent type and rating.
- Never attempt to disconnect the evaluation board from a VTM™ evaluation board while power is applied. This system is not designed to demonstrate the hot-plug capability.

The PRM™ evaluation board can be used to demonstrate a stand-alone buck-boost regulator or in conjunction with a VTM™ evaluation board to enable evaluation of a Factorized Power Architecture™ (FPA™) system. There are many combinations possible using PRM and VTM evaluation boards, but the focus in this user guide is using one PRM evaluation board and one VTM evaluation board, with a brief overview of how to parallel boards.

The PRM module evaluation board can be used to configure various modes of regulation depending upon the application requirements. (1) AL Operation: the PRM uses a unique feed-forward scheme that enables precise regulation of an isolated PoL voltage without the need for remote sensing and voltage feedback. (2) Remote-sense operation: the internal regulation circuitry is disabled and an external control loop and current sensor maintain regulation. This affords flexibility in the design of both voltage and current compensation loops to optimize performance in the end application. In remote-sense operation, PRM can be set in local-sense mode or in non-isolated remote-sense mode depending on the application.

**Table 1**  
Evaluation board numbers  
and their ratings

PRM Part Number (PS10)	Evaluation Board Number	Description	Input Voltage (V)	Output Voltage (V)	Output Power (W)
<a href="#">PRM48AF480T400A00</a>	PRD48AF480T400A00	Full-chip PRM evaluation board	48 (36 – 75)	48 (20 – 55)	400
<a href="#">PRM48BF480T500A00</a>	PRD48BF480T500A00		48 (38 – 55)	48 (20 – 55)	500
<a href="#">MPRM48NF480M500A00</a>	MPRD48NF480M500A00		48 (45 – 55)	48 (20 – 55)	500
<a href="#">PRM48JF480T500A00</a>	PRD48JF480T500A00		User configured		
PRM2A01-xxxxxx	PRD2A01-xxxxxx		User configured		
PRM2A02-xxxxxx	PRD2A02-xxxxxx		User configured		
<a href="#">PRM48BH480T250A00</a>	PRD48BH480T250A00	Half-chip PRM evaluation board	48 (38 – 55)	48 (20 – 55)	250
<a href="#">MPRM48NH480M250A00</a>	MPRD48NH480M250A00		48 (36 – 75)	48 (20 – 55)	200
<a href="#">PRM48AH480T200A00</a>	PRD48AH480T200A00		48 (45 – 55)	48 (20 – 55)	250
<a href="#">PRM48JH480T250A00</a>	PRD48JH480T250A00		User configured		
PRM2A03-xxxxxx	PRD2A03-xxxxxx		User configured		
PRM2A04-xxxxxx	PRD2A04-xxxxxx		User configured		

Refer to the specific PRM data sheet for detail ratings of the device. It is important to remain within the device limits when testing.

These boards make it convenient to evaluate the performance of Vicor PRM products. All evaluation boards include sockets to allow easy "plug and play" insertion and removal of through-hole components and wires while providing kelvin voltage measurements test points of all pins of the PRM. Evaluation boards are designed to simplify testing of the product by providing test points and sockets for easy connection to standard test equipment, lugs for input/output connections, connectors to allow easy insertion and removal of the PRM evaluation board and VTM evaluation board.

Please note that not all evaluation board part numbers have been listed here. Full-chip and half-chip PRMs of different output power level may be using common full-chip and half-chip evaluation boards. Design-specific components have been arranged in Table 5 based on PRM output power level. It is recommended that the user should, first, find out which PRM part number is mounted on evaluation board. Second, please refer to appropriate data sheet for pin functions of PRM and modes of operation. Third, follow the appropriate section of the user guide to use the PRM evaluation board in specific modes of operation.

---

## Contents

All PRM™ evaluation boards arrive with the following contents.  
(The user guide can be downloaded from [www.vicorpower.com](http://www.vicorpower.com))

- 1 x PRM evaluation board
- 1 x VI Chip® push pin heat sink
- 2 x VI Chip push pins for heat sink installation
- 2 x VI Chip push pin heat sink grounding clips
- 1 x hardware kit
- 1 x through-hole aluminum-electrolytic input capacitor (CIN)
- 1 x through hole resistor for default compensation (R28)
- 1 x through hole capacitor for default compensation (C20)
- 2 x jumpers

## Features

1. Input and output lugs for source and load connections
2. Input fuse (appropriately rated)
3. Input filtering and sockets to place through-hole input aluminum-electrolytic capacitor for source decoupling
4. Output filtering and sockets to place through-hole output aluminum-electrolytic capacitor
5. Switch for enabling and disabling the PRM through the ENABLE pin
6. Open drain MOSFET for enabling and disabling the PRM using external source
7. Mode selection switch for various PRM configurations
8. Trim control selection:
  - a. Using potentiometer
  - b. Using fixed resistor
  - c. Using external voltage source
9. Adaptive-loop control selection:
  - a. Using potentiometer
  - b. Using fixed resistor
  - c. Using external voltage source
10. Output current sensing for output current measurement and current feedback in remote-sense operation
11. Sockets and circuits to optimize the external control circuits in remote-sense operation
12. Voltage reference to trim pot for adjusting output voltage set point in remote-sense operation
13. Dual output connectors for transferring the power and signal connections to downstream VTM™ evaluation board
14. Oscilloscope probe jack for making accurate output voltage measurements
15. Dual paralleling connectors for ENABLE, SHARE and SGND signal connections to other PRM evaluation board
16. Kelvin voltage test points and sockets for all pins of PRM
17. Test points for current sensing and AC signal injection (RS mode)
18. Provision for installing the heat sink

## Board Description

The following section provides a detailed description of the evaluation board components, test points and sockets.

**Figure 1**  
Board description

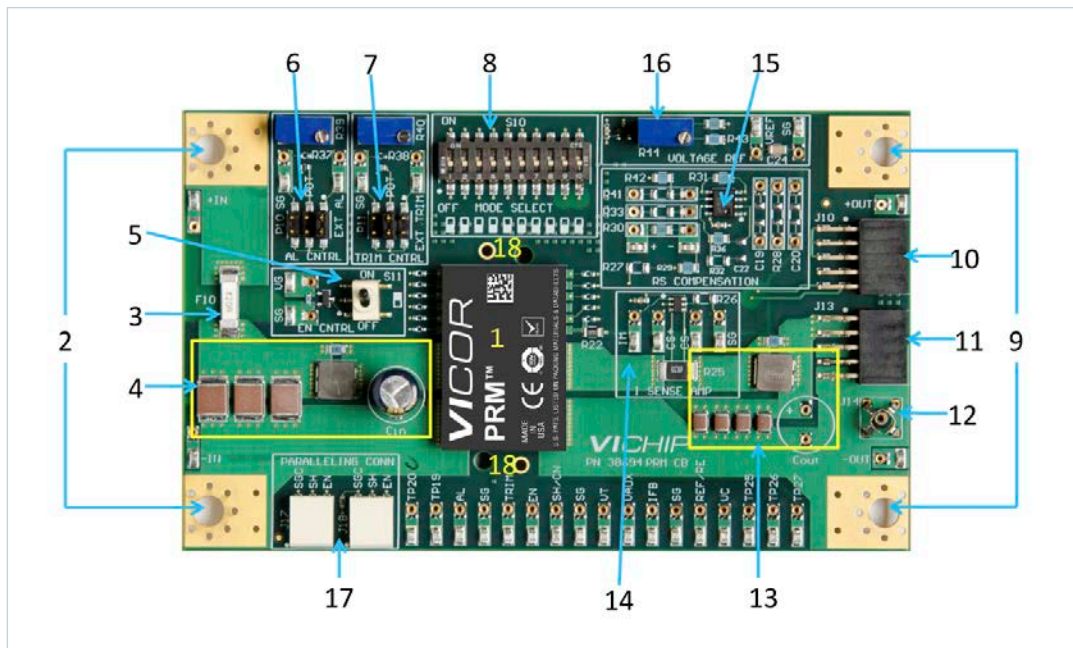

**Figure 2**  
Power/signal connectors pinout  
(front view)

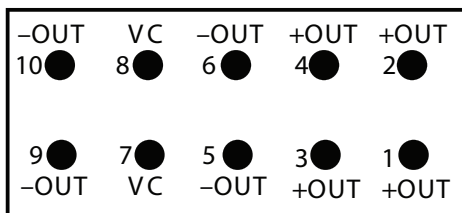

**J13**  
Power/Signal Connector

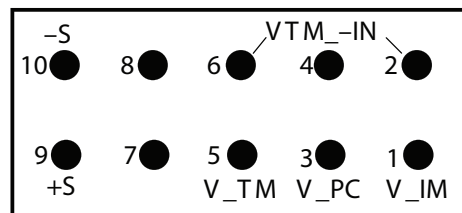

**J10**  
Signal Connector

---

## General Components

1. **PRM™ (PS10)**
2. **Input lugs:** Sized for #10 hardware. Use these for making connection to the input source. This board does not contain reverse polarity protection. Check for proper polarity before applying the power.
3. **Input fuse (F10):** Appropriately rated.
4. **Input filtering:** Input capacitor (CIN) and filtering (inductor and ceramic capacitors) allows for stable operation with most input sources. Sockets can be used for easy installation of aluminum-electrolytic input capacitor. It is recommended to place the 22 $\mu$ F, 100V input electrolytic capacitor in the sockets at the input of the PRM.
5. **Enable/Disable switch (S11) and FET switch:** When actuator is in top position towards "ON" text on the board, the ENABLE pin will be open and PRM device will be enabled. When actuator is in bottom position towards "OFF" text on the board, the ENABLE pin will be connected to SGND and PRM device will be disabled. When switch S11 is ON, open drain FET can be selected to control the ENABLE pin using external source.
6. **Header-jumper for adaptive-loop control (P10):** Provides the option to select and enable adaptive-loop control:
  - a. Using potentiometer (R39)
  - b. Using fixed resistor
  - c. Using external voltage source
7. **Header-jumper for trim control (P11):** Provides the option to select and enable the trim control:
  - a. Using potentiometer (R40)
  - b. Using fixed resistor
  - c. Using external voltage source
8. **Operating Mode selection switch (S10):** For selecting one of the following operating modes:
  - a. Default/adaptive loop
  - b. Child operation (used in PRM paralleling)
  - c. Remote sense: local sensing (single ended)
  - d. Remote sense: non-isolated remote sensing (differential)
9. **Output lugs:** sized for #10 hardware. Use these lugs to connect the output directly to the load.

---

## General Components (Cont.)

10. **Signal connector (J10):** Used to transfer VTM PC, IM, TM, –IN and output sense signals between the PRM™ and VTM™ boards. TM pin of VTM provides feedback to VT pin of PRM to enable temperature compensation in adaptive-loop operation of PRM and VTM.
11. **Power/Signal connector (J13):** Used to transfer power (+OUT/–OUT) and VC to downstream VTM board when used.
12. **Output oscilloscope probe Jack (J14):** Used for making the accurate scope measurements of the output voltage (i.e., ripple). Remove scope grounding lead and insert probe directly into jack ensuring a good connection between the jack and the probe ground barrel. Do not attempt to install while power is applied. May not be compatible with all scope probes.
13. **Output capacitor (COUT) and output filtering (inductor and ceramic capacitors):** Helps to minimize the switching ripple of the output voltage. Sockets can be used for easy installation of aluminum-electrolytic output capacitor.
14. **High-side current-sense resistor and current-sense IC (R25 and U10):** Current-sense shunt monitors the output current and IC provides the feedback to the IFB pin for constant current limit protection in remote-sense operation. Gain is programmed using resistor R26. Constant current limit is set at ~10% above the rated output current of the PRM on all boards.
15. **Voltage sense and error amplifier:** Dual op-amp provides the voltage sensing and error amplifier function. It can be configured for local voltage sensing at the PRM output or a differential amplifier to allow for non-isolated remote sensing at the VTM output or load in remote-sense operation. Sockets are provided for compensation components.
16. **Voltage reference and output voltage trim pot (R44) for external voltage control loop:** remote-sense operation trim pot adjusts the output voltage by increasing and decreasing the error amplifier reference voltage (VREF). Turn clockwise to increase the output voltage and counterclockwise to decrease the output voltage. Sockets can be used for easy installation of soft start ceramic capacitor.
17. **Dual paralleling wire to board connectors (J17 and J18):** Used for transferring signal pins (ENABLE, SHARE and SGND) in parallel operation from one board to other board. Provides simple strip and insert option. Accepts 18-24AWG solid wires. Spring loaded contact will grab solid wire with no need for soldering. Connection requires for parallel regulator operation are grouped together.
18. **Push-pin heat sink and grounding clip mounting holes:** Use these holes for installing the optional push pin heat sink and grounding clips included with the board. Use of the heat sink with fan is highly recommended for appropriate cooling of the PRM module.

## Test Points Description

Each test point has a socket which accepts 0.015 – 0.025 inch diameter leads for easy installation of solid wires and through-hole components. All the test points are brought out to the edge of the board to allow for easy measurement and/or connection to the user's external circuitry. All test points are labeled and routed to the edge of the board. Each test point is accompanied with an adjacent socket for adding a test lead or to facilitate wiring to external circuitry.

**Table 2**  
Test points description

Reference Designator	Functional Name	Functional Description
TP30 TP33	+IN -IN	Input voltage test points provide Kelvin connection to input pins of the PRM™. Use these test points for measuring the input voltage of the PRM to avoid error due to interconnect losses.
TP31 TP32	+OUT -OUT	Output voltage test points provide Kelvin connection to output pins of the PRM. Use these test points for measuring the output voltage of the PRM to avoid error due to interconnect losses.
TP34 TP21 TP22	SGND	Signal Ground (SGND) test points are the ground reference for all control circuitry and signal pins of the PRM.
TP28 TP29	CS+ CS-	Used to measure the output current of the PRM across shunt resistor R25.
TP35 TP36	IM SG	Used to measure the output of current sense IC with reference to SGND.
TP10	SHARE / CONTROL NODE	Used to measure the SHARE/CONTROL NODE signal of the PRM with reference to SGND test point.
TP11	AL	Used to measure the AL signal of the PRM with reference to SGND test point in adaptive-loop operation.
TP12	TRIM	Used to measure the TRIM signal of the PRM with reference to SGND test point in adaptive-loop operation.
TP13	VAUX	Used to measure the VAUX signal of the PRM with reference to SGND test point.
TP14	REF / REF_EN	Used to measure the REF/REF_EN signal of the PRM with reference to SGND.
TP15	VT	Used to measure the VT signal when connected to VTM™ TM pin with reference to SGND in adaptive-loop operation.
TP16	ENABLE	Used to measure the ENABLE signal with reference to SGND.
TP17	VC	Used to measure the VC signal with reference to SGND.
TP18	IFB	Used to measure the IFB signal of the PRM with external constant-current circuit with reference to SGND in remote-sense operation.
TP43 TP44	VREF	Used to measure the voltage reference signal of the error amplifier with reference to SGND in remote-sense operation.
TP19 TP20	NC	No connect. For internal use only.
TP37 TP38		Can be used to inject the isolated signal of network analyzer for bode plot measurement to measure the stability in remote-sense operation.
TP23 TP24	VG SG	Can be used to connect function generator to control the open drain MOSFET in ENABLE control.
TP39 TP41	EXT AL SG	Can be used to enable adaptive-loop control using external source when AL control is selected using header P10 and jumper.
TP40 TP42	EXT TRIM SG	Can be used to enable TRIM control using external source when TRIM control is selected using header P11 and jumper.



## Sockets Description

Each socket accepts 0.015 – 0.025 inch diameter leads for easy installation of solid wires and through-hole components for use with external circuit and test equipment.

**Table 3**  
Sockets description

Reference Designator	Functional Name	Functional Description
H57 H58	Input Capacitor (CIN)	Sockets are used for easy installation of through-hole 100V-rated aluminum-electrolytic capacitor.
H32 H33	Output Capacitor (COUT)	Sockets are used for easy installation of through-hole 100V-rated aluminum-electrolytic capacitor. Ensure proper polarity with short leads while installing.
H49 H53	AL Resistor (R37)	Used for easy installation of fixed through-hole resistor between AL and SGND pins of the PRM when jumper is placed on Pin1 and Pin2 of the P10 header. Used only with adaptive loop and default switch S10 configuration.
H50 H54	Trim Resistor (R38)	Used for easy installation of fixed through-hole resistor between TRIM and SGND of the PRM™ when jumper is placed on the Pin1 and Pin2 of the P11 header. Used only with adaptive loop and default switch S10 configuration.
H41 H43	Compensation Capacitor (C20)	Used for easy installation of through-hole compensation capacitor C20 in feedback path of error amplifier. Default through-hole 4700pF capacitor is added in the box. Used only with remote-sense operation.
H42 H44	Compensation Resistor (R28)	Used for easy installation of the through-hole compensation resistor R28 in feedback path of the error amplifier. Default through-hole 20kΩ resistor is added in the box. Used only with remote-sense operation.
H39 H40	Integrator Capacitor (C19)	Used for easy installation of through-hole compensation capacitor C19.
H47 H48	Differential Input Resistor (R33)	Used for easy installation of through-hole resistor R33 for non-isolated differential sensing in remote-sense operation.
H51 H52	Differential Input Resistor (R41)	Used for easy installation of through-hole resistor R41 for non-isolated differential sensing in remote-sense operation.
H55 H56	Soft-Start Capacitor (C24)	Used for easy installation of the through-hole capacitor on top of default 0.1 μF to soft-start the PRM output voltage in remote-sense operation.
H46 H45		Used to insert wires to hook up the network analyzer measuring probes to measure stability in remote-sense operation.
H30 H31	CS+ CS-	Used to insert test leads to measure the voltage across R25.



# Schematic

Schematic for half-chip and full-chip PRM™ evaluation board is same.

**Figure 3a**  
PRM evaluation board schematic

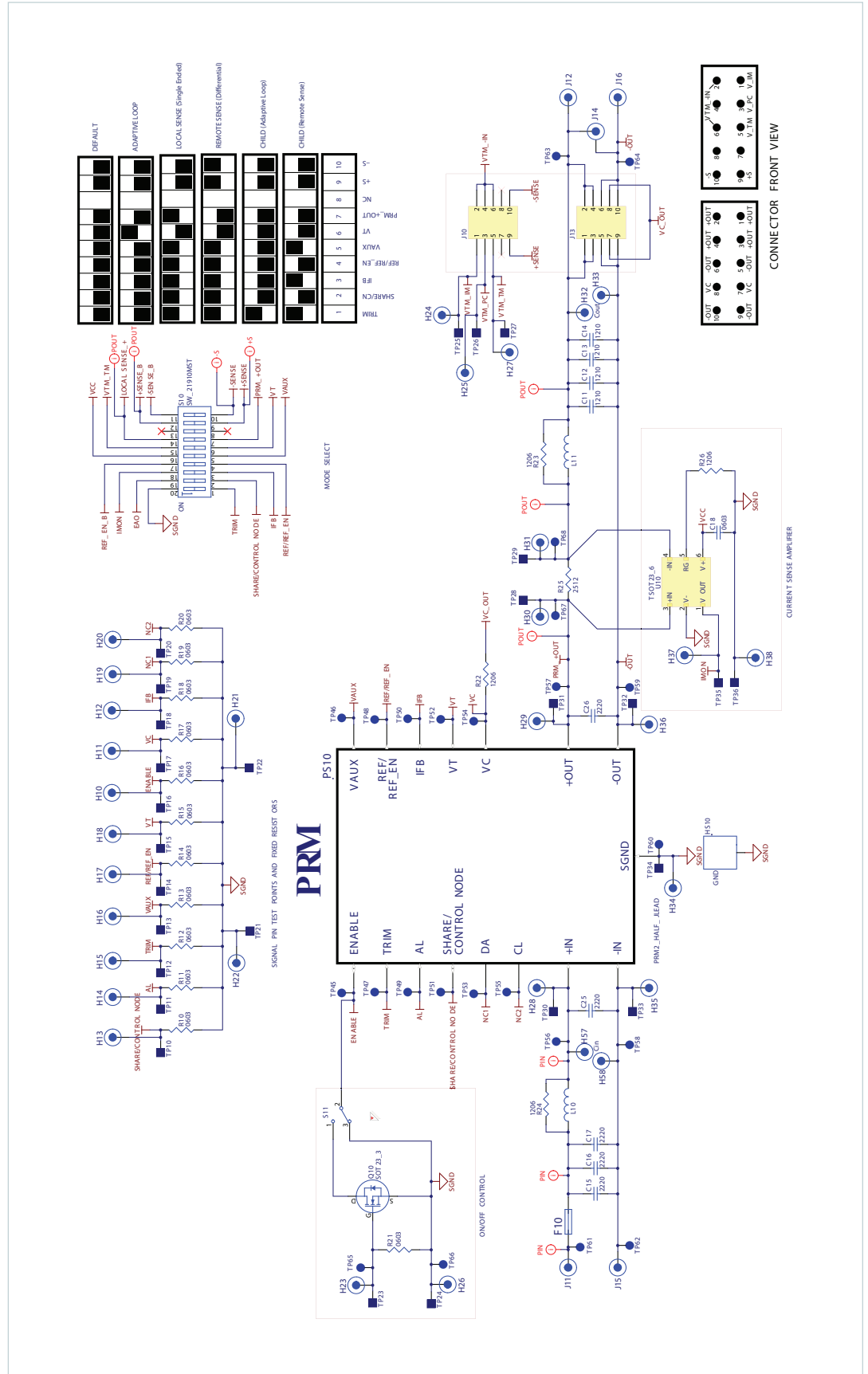

# Schematic (Cont.)

**Figure 3b**  
PRM evaluation  
board schematic

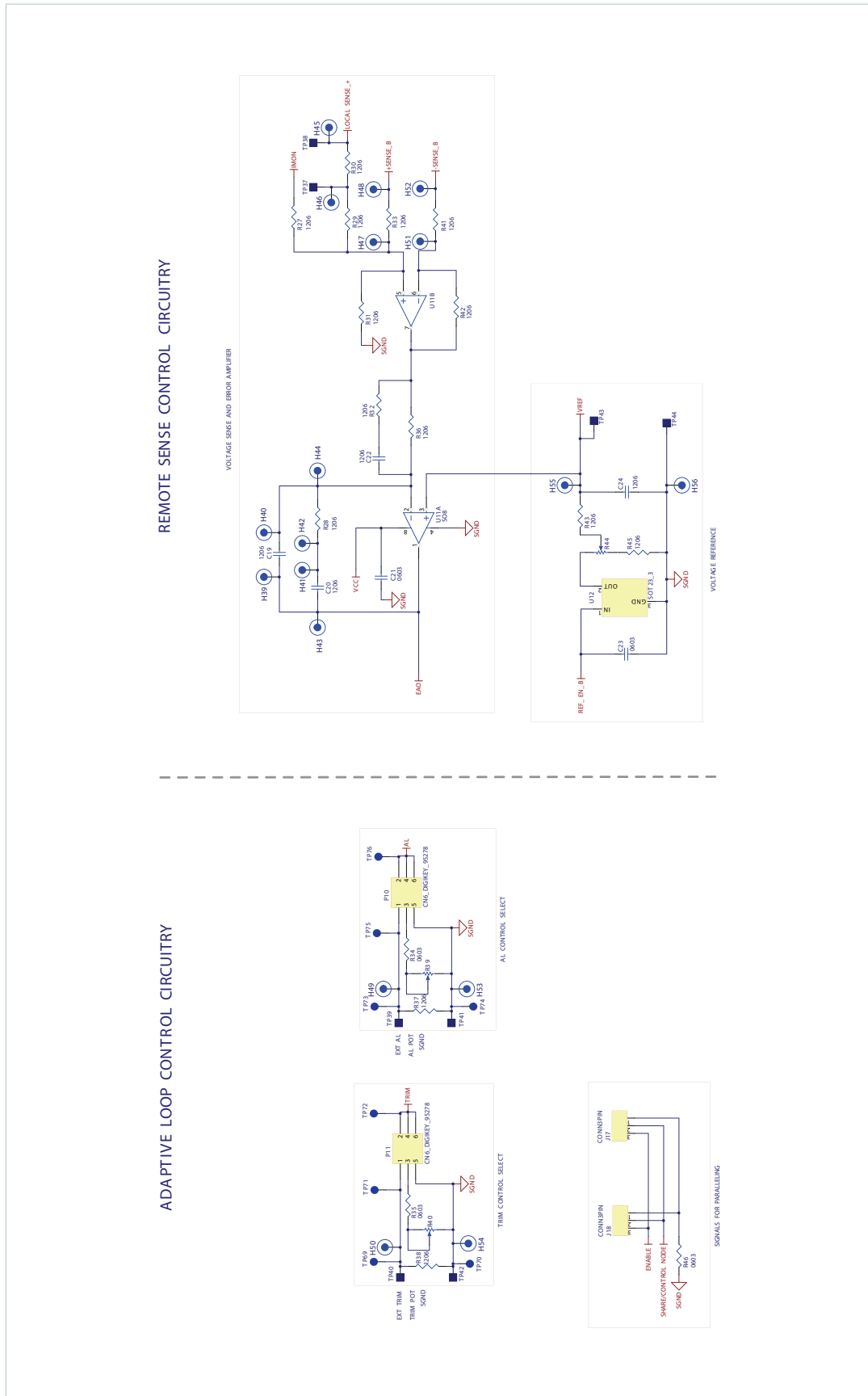

## Assembly Drawings

**Figure 4a**

Top view: half-chip evaluation board assembly drawing

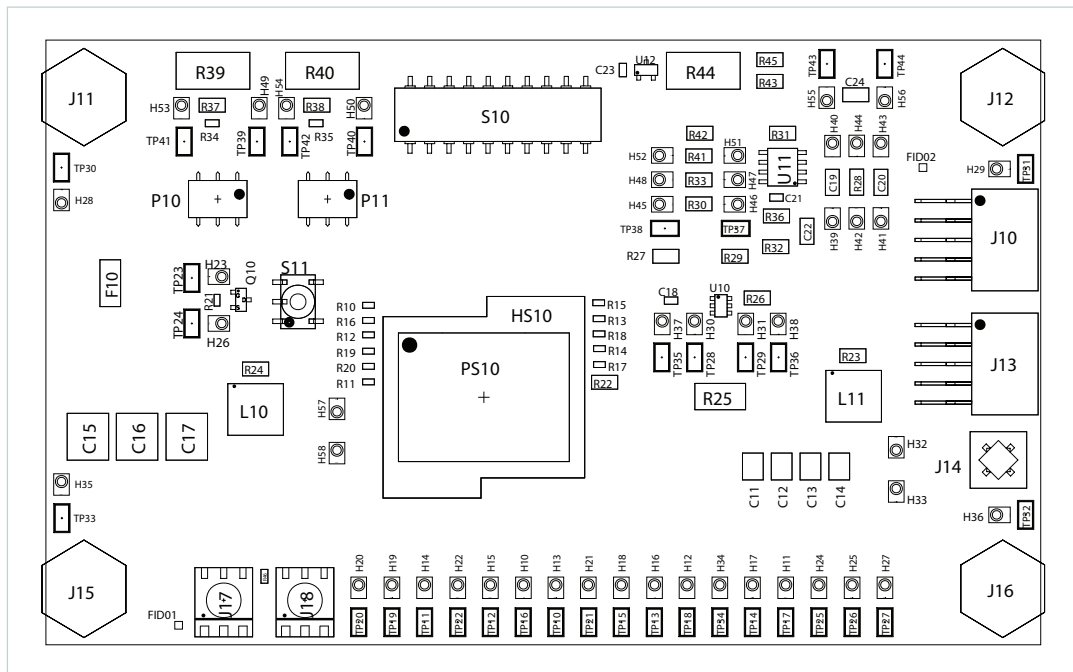

**Figure 4b**

Top view: full-chip evaluation board assembly drawing

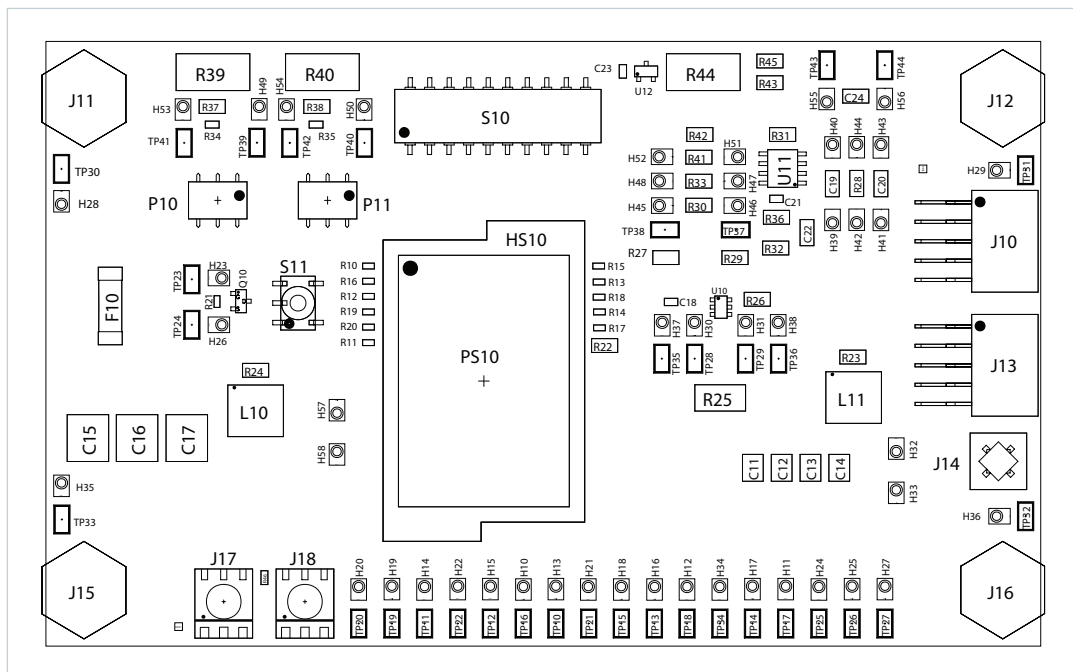

## Assembly Drawings (Cont.)

**Figure 4c**  
Bottom view:  
half-chip / full-chip evaluation  
board assembly drawing

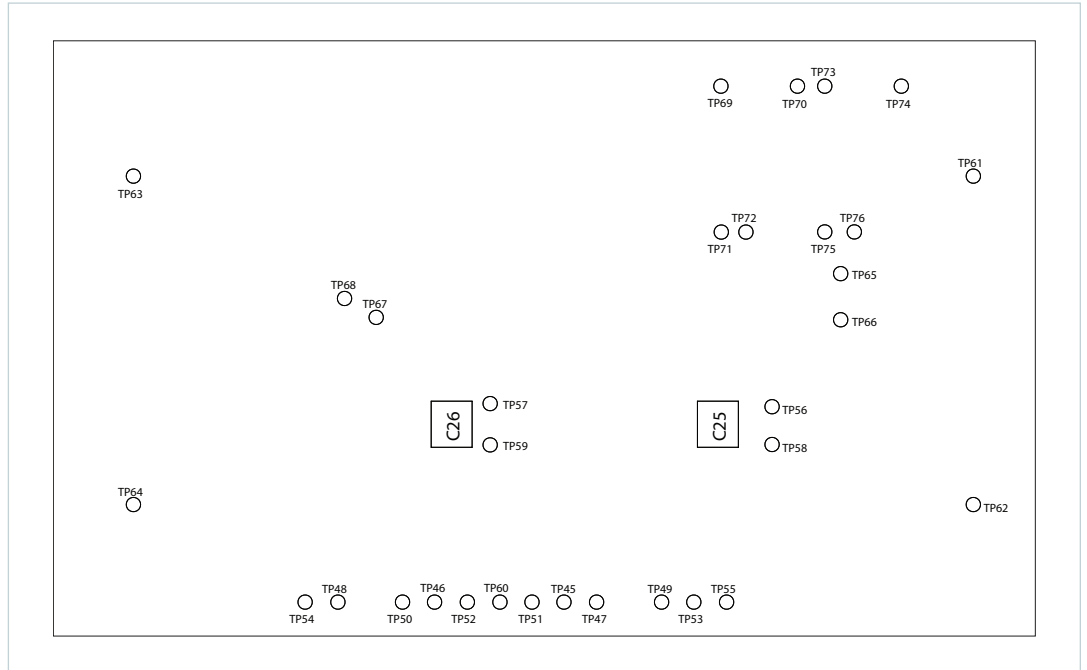

## Bill of Materials

Following table describes the most common components of all four versions of PRM™ evaluation boards.

**Table 4**  
Common components

Reference Designator	Description	Manufacturer	Manufacturer Part Number
C11, C12, C13, C14	CAP X7R 2.2μF 10% 100V 1210 .102 MAX HT	TDK Corp. of America	C3225X7R2A225KT5LOU
C15, C16, C17	CAP X7R 4.7μF 20% 100V 2220	TDK	C5750X7R2A475M
C18, C21, C23	CAP X7R 0.01μF 10% 100V 0603	MURATA	GRM188R72A103KA01J
C20* not applied—use sockets	CAP X7R 4700pF 10% 50V RADIAL	AVX CORP	SR155C472KAR
C24	CAP X7R 0.10μF 10% 100V 1206	AVX CORP	12061C104KATMA
CIN	CAP ALEL 22μF 20% 100V RADIAL 8 X 11.5	PANASONIC	EEU-FC2A220
F10	Design specific – see Table 5		
H10 to H58	PIN RECPT 0.015/0.025 DIA 0667 SER TH	MILL-MAX MFG CORP	0667-0-57-15-30-27-10-0
J10, J13	CONN 10 PINS 2.54MM PITCH DUAL ROW SM HO	GCT	BG225-10-A-N-A
J14	JACK VERTICAL MECH THRU HOLE	TEKTRONIX	131-5031-00
J17, J18	CONN 3 POS WIRE TO BOARD SMD	AVX CORP	478-6170-2-ND
JUMPER_HEADER	JUMPER SOCKET XJ8A	OMRON ELECTRONICS	XJ8A-0211
L10, L11	IND 0.1μH 20% 32.5A 2525	VISHAY/DALE	IHLP2525CZERR10M01
P10, P11	HEADER 6 PIN STRAIGHT SMT	FCI	95278-101A06LF
PCB	Design specific – see Table 5		
PS10	Design specific – see Table 5		
Q10	FET 2N7002 SOT-23	ON SEMICONDUCTOR	2N7002LT1G
R21	RES 10kΩ 1/10W 1% 0603	KOA SPEER	RK73H1J1002FTD
R22	RES 0Ω JUMPER 2A 1206	KOA SPEER	RK73Z2BTDD
R23, R24	RES 1Ω 1/4W 5% 1206	KOA SPEER	RK73B2BTTE1R0J
R25	Design specific – see Table 5		

## Bill of Materials (Cont.)

Following table describes the most common components of all four versions of PRM™ evaluation boards.

**Table 4 (Cont.)**  
Common components

Reference Designator	Description	Manufacturer	Manufacturer Part Number
R26	Design specific – see Table 5		
C28* not applied– use sockets	RES 20kΩ 1/4W 1% AXIAL	KOA SPEER	MF1/4DCT52R2002F
R29	RES 54.9kΩ 1/4W 1% SMD 1206	KOA SPEER	RK73H2BTTE5492F
R30	RES 20Ω 1/4W 1% 1206	KOA SPEER	RK73H2BTTD20R0F
R31, R42	RES 1.27kΩ 1/4W 1% SMD 1206	KOA SPEER	RK73H2BTTE1271F
R34	RES 0Ω JUMPER 1A 0603	KOA SPEER	RK73Z1JTDD
R35	RES 4.32kΩ 1/10W 1% 0603	KOA SPEER	RK73H1J4321FTD
R36	RES 1kΩ 1/4W 1% 1206	KOA SPEER	RK73H2BTTE1001F
R39, R40	RES TRIM POT 100kΩ 1/2W 10% TH	MURATA	PV36Y104C01B00
R43	RES 10kΩ 1/4W 1% 1206	KOA SPEER	RK73H2BTTE1002F
R44	RES TRIM POT 10kΩ 1/2W 10% TH	COPAL ELECTRONIC	CT94EY103
R45	RE 5.62kΩ 1/4W 1% SMD 1206	KOA SPEER	RK73H2BTTE5621F
R46	RES 1Ω 1/10W 1% 0603	PANASONIC	ERJ-3RQF1R0V
S10	MECH SMD 10-POS DIP SWITCH	CTS ELECTROCOMPONENTS	219-10MSTRF
S11	SW TOGGLE SPDT 1 POS SMD	C & K COMPONENTS	GT11MSCBE
TP10 to TP44	TEST POINT, SURFACE MOUNT	KEystone	5017
U10	IC HV I SENSE LMP8645HV TSOT-6	NATIONAL SEMICONDUCTOR	LMP8645HVMKE/NOPB
U11	IC DUAL OPAMP LM6142AIM 8PIN SO	NATIONAL SEMICONDUCTOR	LM6142AIMNOPB
U12	IC VREF 1.25V REF3312 SOT23 3	TI	REF3312AIDBZT

Please note that R28 and C20 are through-hole default compensation components required for Remote-Sense operation.

## Bill of Materials (Cont.)

Following table describes the most common components of all four versions of PRM™ evaluation boards.

**Table 5**  
Board-specific components

Reference Designator	Description	Manufacturer	Manufacturer Part Number
<b>Board-Specific Components</b>			
<b>Evaluation board numbers: PRD48AF480T400A00 and PRD2A02-xxxxxx</b>			
PS10	PRM2A FULL WIDE 400W	VICOR	PRM48AF480T400A00 or PRM2A02-xxxxxx (user configured)
R26	RES 215kΩ 1/4W 1% 1206	KOA SPEER	RK73H2BTTE2153F
R25	RES I SENSE 5mΩ 1W 1% 2512	VISHAY	WSL25125L000FEA
F10	FUSE 20A 125V <sub>AC</sub> FAST 10.1X3.1 SMD	LITTELFUSE	0456020.ER
PCB	SINGLTD PCB FULL PRM CONFIG CB	VICOR	39573
<b>Evaluation board numbers: PRD48BF480T500A00, PRD2A01-xxxxxx, PRD48JF480T500A00 and MPRD48NF480M500A00</b>			
PS10	PRM2A FULL NARROW 500W	VICOR	PRM48BF480T500A00 or PRM2A01-xxxxxx (user configured) or PRM48JF480T500A00 or MPRM48NF480M500A00
R26	RES 174kΩ 1/4W 1% 1206	KOA SPEER	RK73H2BTTE1743F
R25	RES I SENSE 5mΩ 1W 1% 2512	VISHAY	WSL25125L000FEA
F10	FUSE 20A 125V <sub>AC</sub> FAST 10.1X3.1 SMD	LITTELFUSE	0456020.ER
PCB	SINGLTD PCB FULL PRM CONFIG CB	VICOR	39573
<b>Evaluation board numbers: PRD48AH480T200A00 and PRD2A04-xxxxxx</b>			
PS10	PRM2A HALF WIDE 200W	VICOR	PRM48AH480T200A00 or PRM2A04-xxxxxx (user configured)
R26	RES 215kΩ 1/4W 1% 1206	KOA SPEER	RK73H2BTTE2153F
R25	RES I SENSE 10mΩ 3W 1% 2512	BOURNS	CRA2512-FZ-R010ELF
F10	LITTLE FUSE 10A R451010.MRL	LITTELFUSE	0451010.MRL
PCB	SINGLTD PCB HALF PRM CONFIG CB	VICOR	38693
<b>Evaluation board numbers: PRD48BH480T250A00, PRD2A03-xxxxxx , PRD48JH480T250A00 and MPRD48NH480M250A00</b>			
PS10	PRM2A HALF NARROW 250W	VICOR	PRM48BH480T250A00 or PRM2A03-xxxxxx (user configured) or PRM48JH480T250A00 or MPRM48NH480M250A00
R26	RES 174kΩ 1/4W 1% 1206	KOA SPEER	RK73H2BTTE1743F
R25	RES I SENSE 10mΩ 3W 1% 2512	BOURNS	CRA2512-FZ-R010ELF
F10	LITTLE FUSE 10AP R451010.MRL	LITTELFUSE	0451010.MRL
PCB	SINGLTD PCB HALF PRM CONFIG CB	VICOR	38693



## VTM™ Evaluation Boards

The PRM™ evaluation board is designed to work with all types of VTM evaluation boards to facilitate testing of virtually any PRM/VTM combination. The VTM evaluation board contains dual connectors designed to mate with J10 and J13 on PRM evaluation board. The additional signal connector is used to transfer VTM signal pins, as well as S+ and S– signals between boards. The S+ and S– signals are tied to the VTM output using local sense resistors and can be used for implementing non-isolated remote sense as described in a later section. Board also provides the ability to inject an AC signal for measuring the loop response and break the isolation for non-isolated remote sense using PRM and VTM. The TM feedback of the VTM is also transferred through the additional signal connector to make connection with VT pin of the PRM to enable temperature compensation in adaptive-loop configuration.

**Figure 5**  
VTM evaluation board

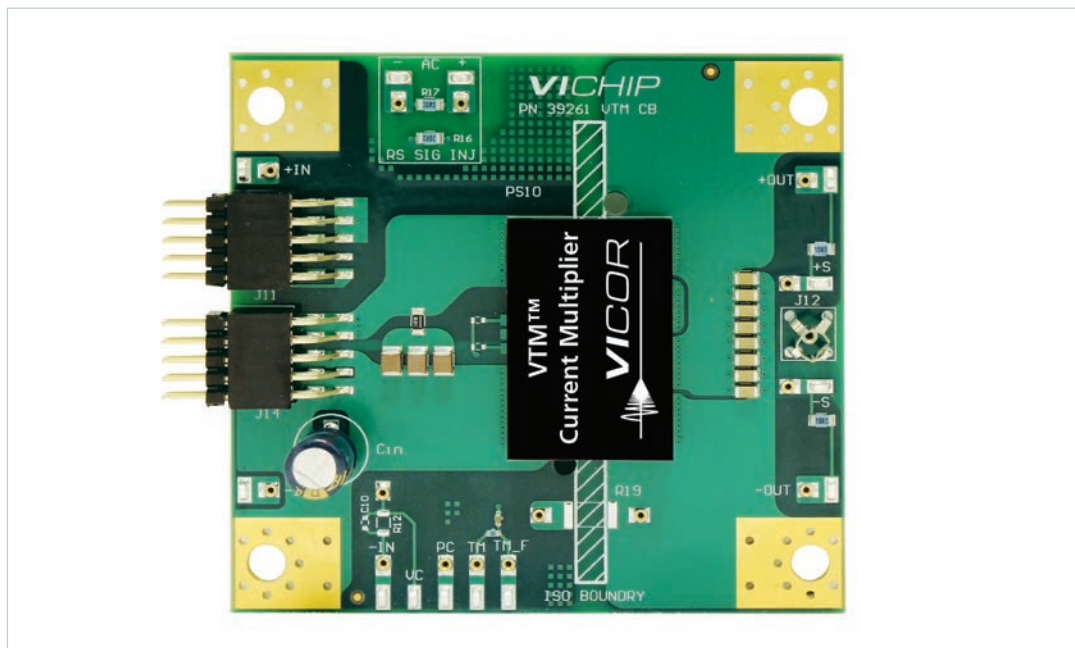

**Figure 6**  
VTM evaluation board  
connector pinout (front view)

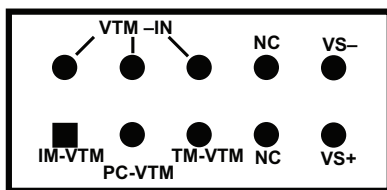

VTM Evaluation Board  
Signal Connector

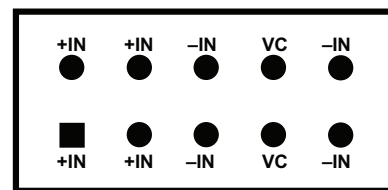

VTM Evaluation Board  
Power / Signal Connector

**Figure 7**  
PRM evaluation board  
connection to  
VTM evaluation board

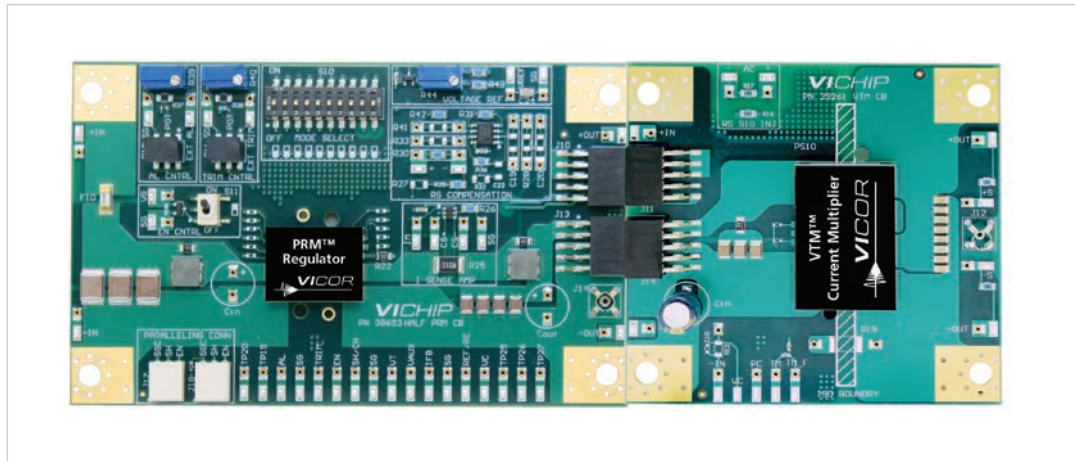

## Recommended Test Equipment

The following is a list of recommended test equipment.

1. DC power supply: 0 – 80V, 600W minimum
2. Load: Rated appropriately based on output voltage, current and power requirements.
3. Digital multi-meters (DMMs)
4. Oscilloscope + probes
5. Function generator (for external enable/disable and trim control)
6. Auxiliary bench voltage supply (for external trim and AL control)
7. Network analyzer (remote-sense operation)
8. Interconnect wires, cables and fastening hardware.
9. Calibrated input and output shunts, appropriately rated (for efficiency measurements)
10. Trim pot screwdriver
11. Fan
12. Data sheets of requisite PRM™ and VTM™ device used.
13. Safety glasses
14. Thin-bladed tool for wire extraction from paralleling connectors (AVX part number: 06-9276-7001-01-000)

## Push-Pin Heat Sink Installation

Each PRM and VTM evaluation board comes with its own heat sink and push pins for installation. Before testing, it is highly recommended that heat sinks be installed in the appropriate location for each board. When installing the push-pin heat sink, use caution not to exceed the maximum compressive on the device listed in the data sheet.

## Line and Load Connections

- Make sure that input power supply is OFF.
- Connect the input power supply positive lead to the +IN input lug of the evaluation board.
- Connect the input power supply return lead to the –IN input lug of the evaluation board.
- Connect the output lug +OUT to the positive terminal of the electronic load.
- Connect the output lug –OUT to the return terminal of the electronic load.
- Verify proper polarity of the connections.
- Place the input capacitance 22 $\mu$ F, 100V.
- Turn the FAN ON.
- Have the latest version of the data sheet.

## Board Operating Modes

PRM™ evaluation board supports both adaptive-loop and remote-sense operation. Therefore, operating mode selection switch S10 is provided on the board for selection of the following operating modes:

- Default / adaptive loop using PRM
- Adaptive loop using PRM and VTM
- Remote sense: local sensing (single ended)
- Remote sense: non-isolated remote sense (differential)
- Child (for array operation)

**Figure 8**  
Mode-select switch

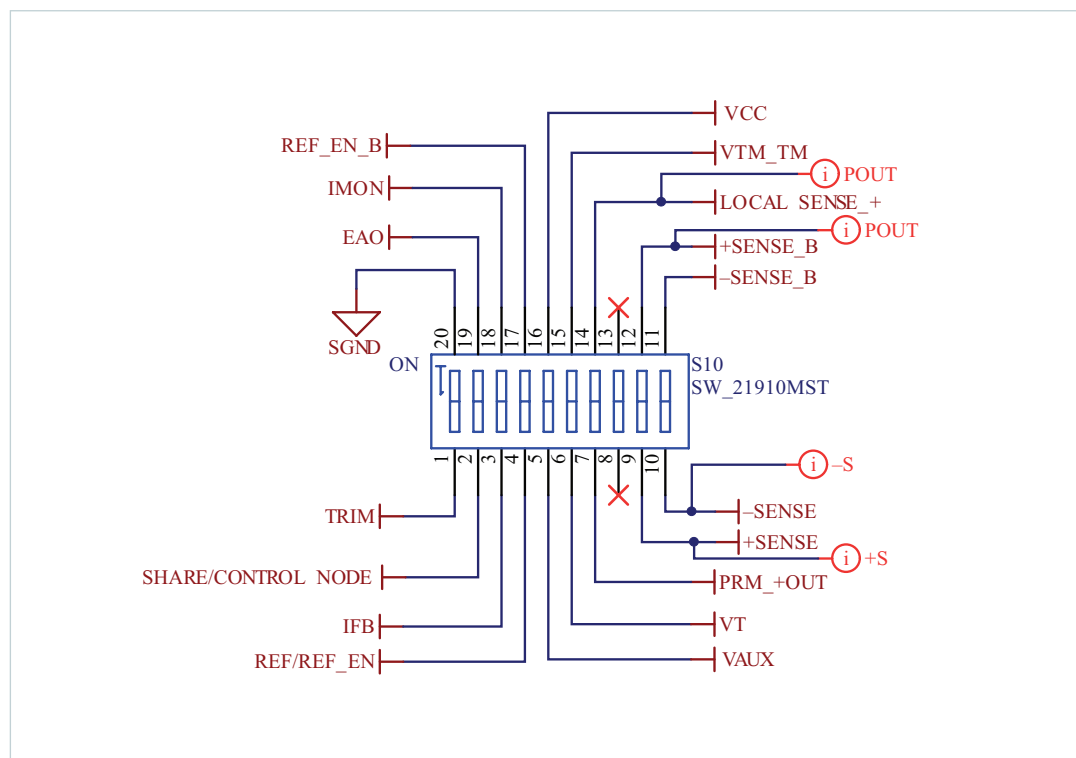

**Figure 9**  
Switch configuration

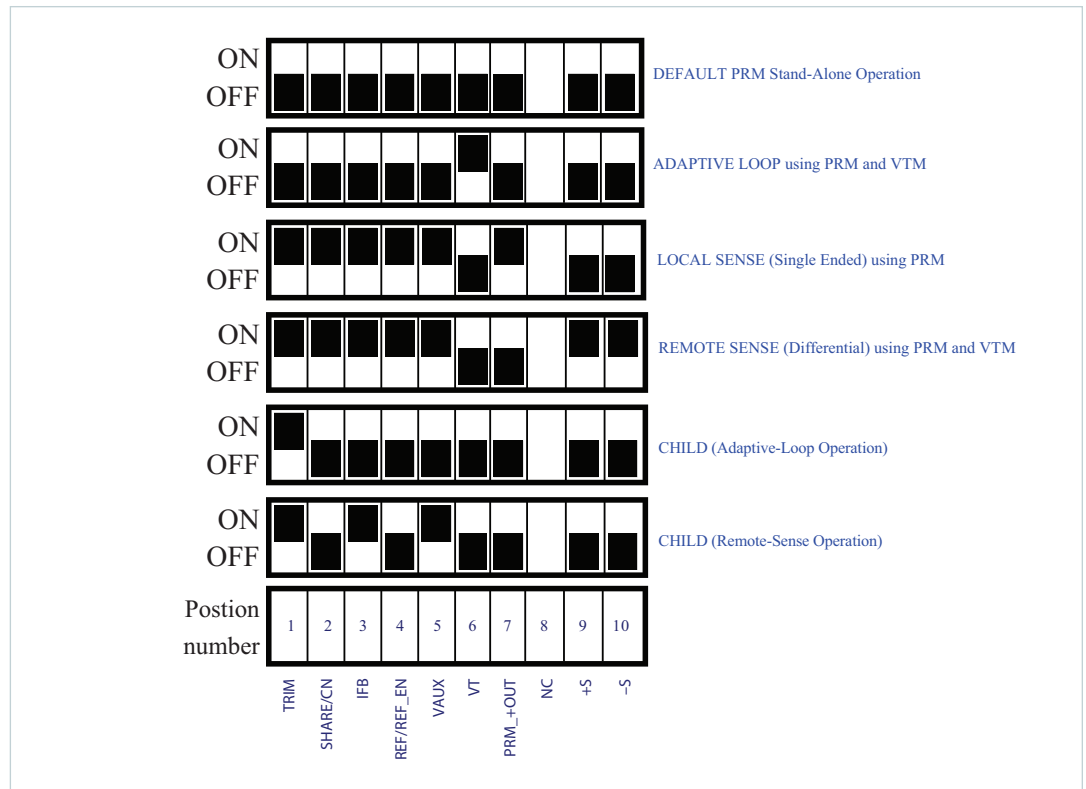
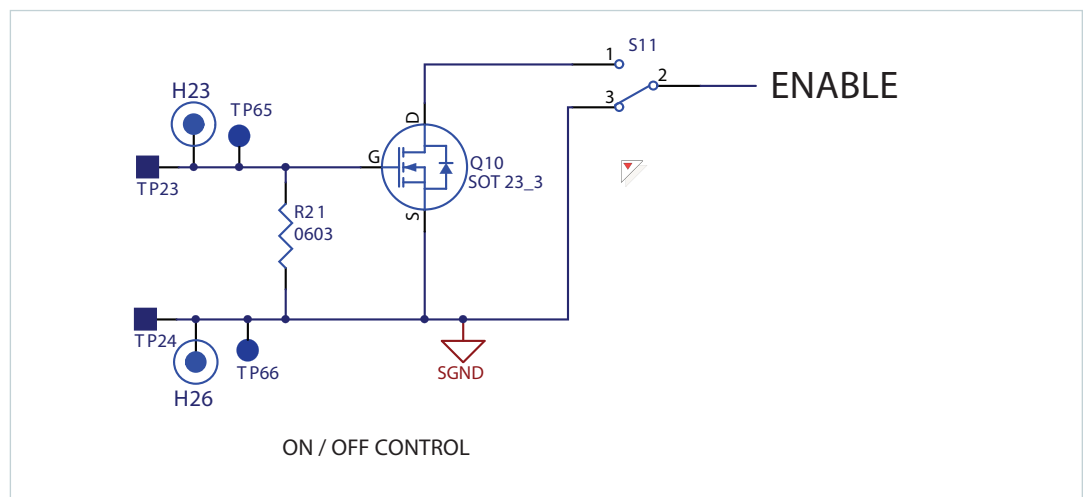

Figure 9 provides the illustration for how to configure the switch for each operating mode.

### Common Features in All Modes of Operation

- On / off control to enable and disable the PRM™ in the presence of input power.
  - Using switch S11 or
  - Open drain MOSFET using external circuitry or function generator
- Input filtering (inductor and ceramic capacitors)
- Output filtering (inductor and ceramic capacitors)
- Sockets for easy installation of input and output electrolytic capacitor
- Test points for current sensing
- Kelvin test points for measurement of input voltage, output voltage and all signal pins of the PRM.
- Sockets for each test point for easy installation of through-hole components and solid wires to facilitate the wiring to external circuitry and test equipment.

**Figure 10**  
ON / OFF control



## Default PRM™ Stand-Alone Operation

Mode select switch S10 setting: keep the switch OFF at all positions as shown in following illustration. Please note that switch S10 is a ten-position switch.

**Figure 11**  
Ten-position switch settings for default / adaptive-loop

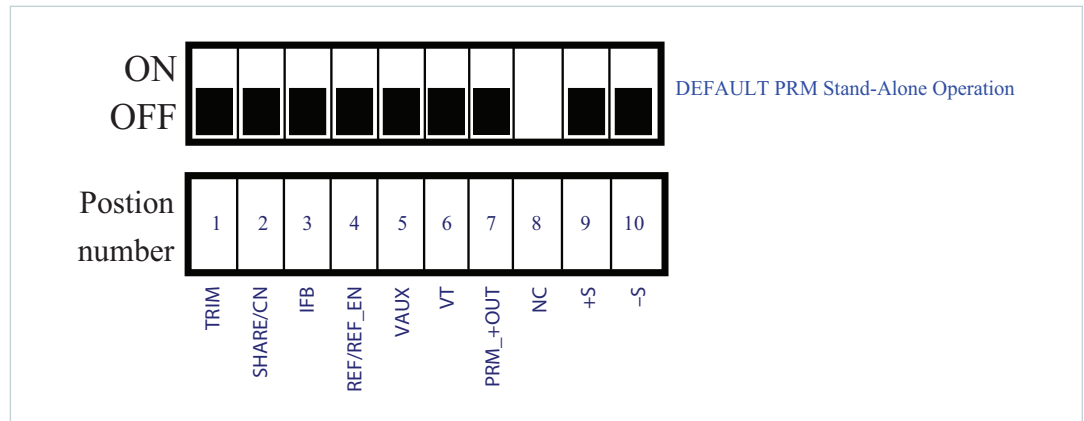

In default operation, PRM maintains its own output voltage using active internal voltage sensing. Also internal current sensing circuit is active for constant current limit. In adaptive-loop operation, AL control programs the load line to compensate resistive drops from the PRM output voltage to point of Load. Trim control sets the output voltage other than the default 48V in the range of 20 – 55V.

### Default/Adaptive-Loop Controls

Trim control: Jumper and header select either external trim, trim POT, Trim to SGND option or none. Place jumper across correct position in P11 to enable trim control. Please note that R38 – 1206 resistor footprint is not populated in trim control. Instead, External trim provides option to select sockets for easy installation of fixed resistor or surface mount test points to apply external voltage source.

Trim control provides the option to select the potentiometer R40 using proper jumper setting on header P11 in default / adaptive-loop operation. Rotate POT R40 clockwise to increase the TRIM pin voltage and counterclockwise to decrease the TRIM pin voltage. Trim control allows setting the TRIM pin voltage in the range of 1 – 2.75V to set the output voltage between 20 and 55V.

**Figure 12**  
Trim control selection

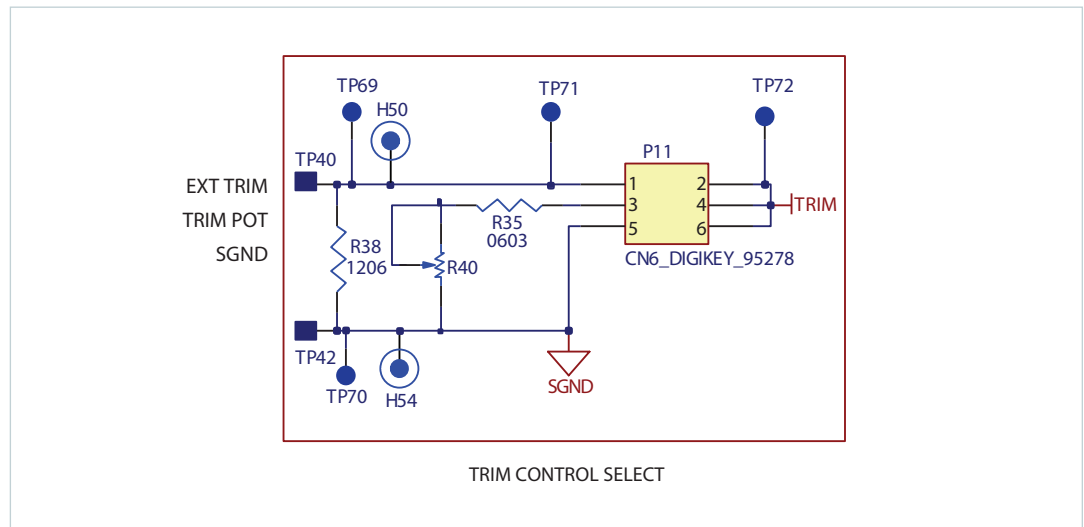

Adaptive-loop control: Jumper and header select either external AL, AL POT, AL to SGND option or none. Place jumper across correct position in P13 to enable AL control. Please note that R37 – 1206 resistor footprint is not populated in AL control. Instead, External AL provides option to select sockets for easy installation of fixed resistor or surface mount test points to apply external voltage source.

AL control provides the option to select potentiometer R39 using proper jumper setting on header P10. Rotate POT R39 clockwise to increase the AL pin voltage and counterclockwise to decrease the AL pin voltage. AL control allows setting the AL pin voltage in the range of 0 – 3V to program the PRM load line for adaptive-loop operation.

**Figure 13**  
Adaptive-loop selection

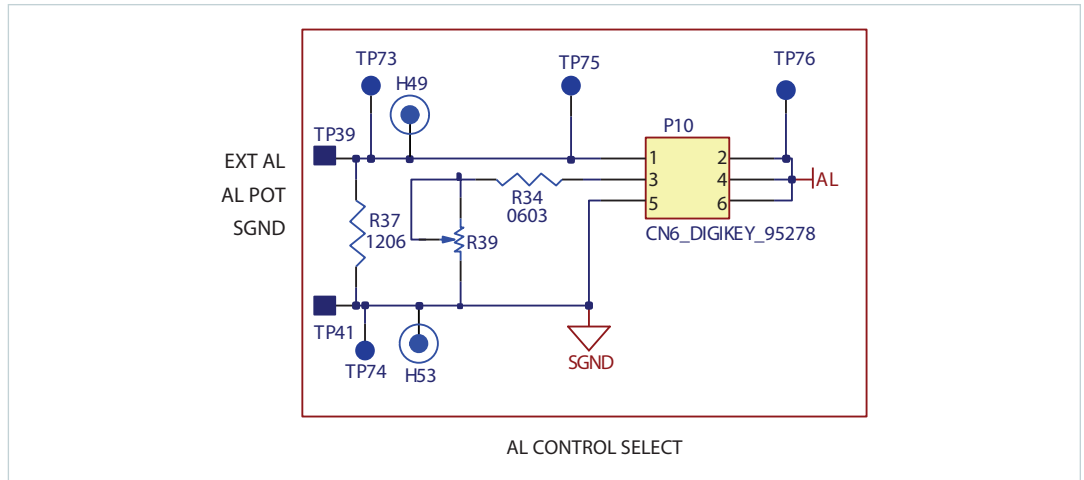

### Adaptive-Loop Operating Mode Using PRM™ and VTM™

Mode select switch S10 setting: keep the switch S10 setting at all positions as shown in following illustration.

**Figure 14**  
Switch settings for PRM and VTM adaptive loop

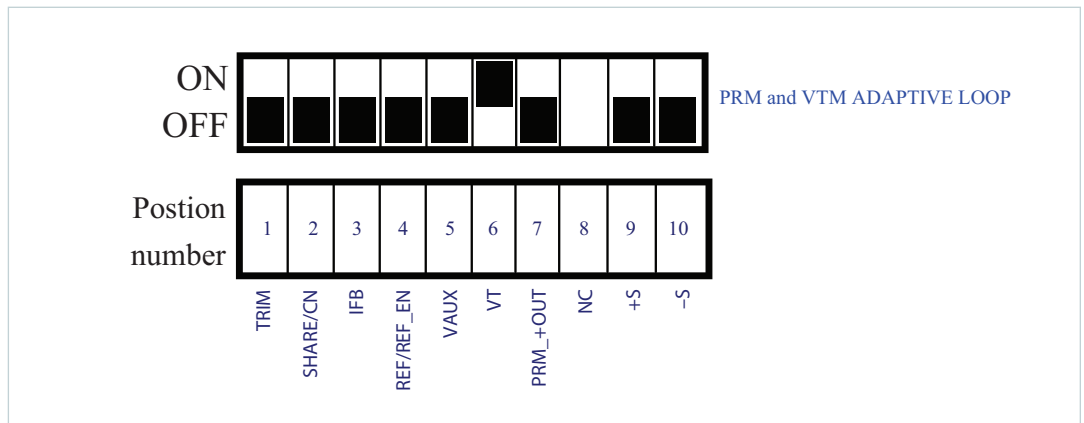

For use when VTM evaluation board is connected to PRM evaluation board. Switch at position 6 is ON, the TM signal of the VTM is transferred through the additional signal connector to make connection with VT pin of the PRM to enable temperature compensation in adaptive-loop operation. Other features remain the same in this mode of operation as mentioned in previous mode of operation.

### Remote-Sense Operating Mode Using PRM: Local Sensing (Single Ended)

Mode select switch S10 setting: keep the switch S10 setting at all positions as shown in following illustration.

**Figure 15**  
Switch settings for local sense

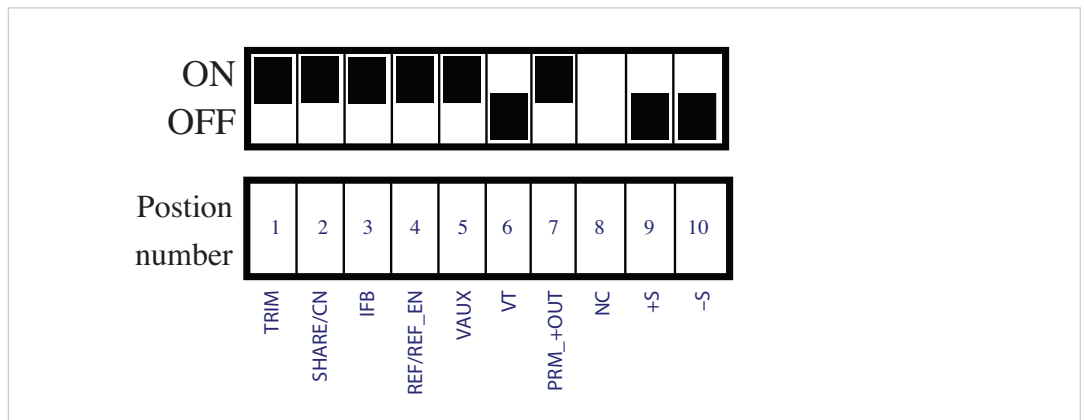

The following table describes the switch configuration.

**Table 6**  
Switch configuration in local sensing

Switch Position Number	ON / OFF	Connection
1	ON	TRIM pin is shorted to GND and PRM is configured for remote-sense operating mode.
2	ON	CONTROL NODE pin is connected to output of external error amplifier.
3	ON	IFB pin is connected to output of external current-sense amplifier to set constant-current limit.
4	ON	REF_EN pin is connected to input of the external voltage reference circuit to generate voltage reference for external error amplifier.
5	ON	VAUX pin is connected to power VCC of the op-amp and current-sense IC.
6	OFF	TM pin of the VTM is not connected to VT pin of the PRM.
7	ON	PRM +OUT pin is connected to local sense (single ended) of the remote-sense control circuitry.
8	either	
9	OFF	See next remote-sense operation
10	OFF	See next remote-sense operation

**Figure 16**  
Remote sense: local-sensing (single-ended) control circuitry  
**BLUE highlight** = Pre-installed component  
**GREEN highlight** = user-installed component

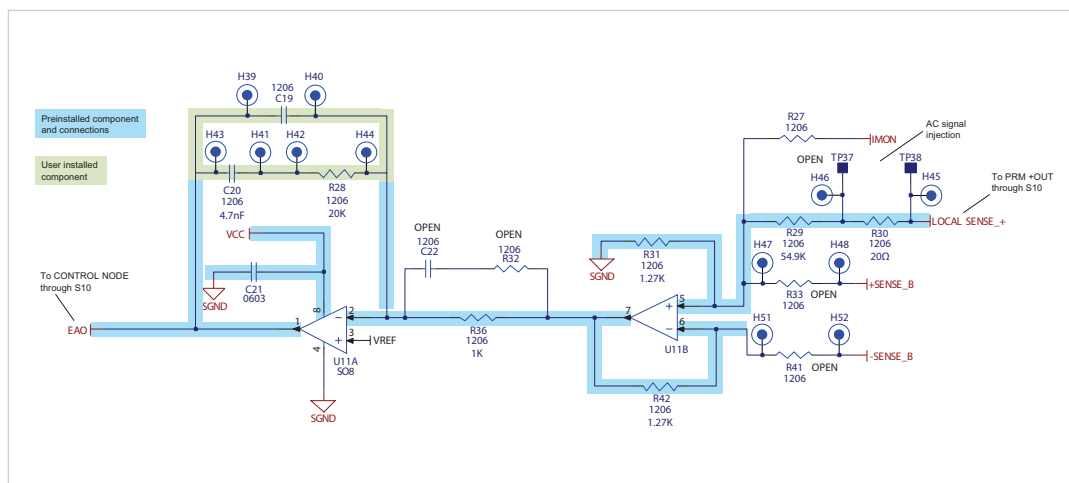

In this configuration, PRM operates in remote sense. PRM module output voltage is sensed through divider formed by R29 and R31. U11B is configured as buffer as shown in Figure 13 and provides the sense voltage to error amplifier U11A. R33, R41 and R27 are left open, reserved for differential sensing and current sensing. R29 is set to limit the upper trim range based on a maximum reference voltage of 1.25V. Note that by default compensation components are not installed and required for operation. Default compensation components are provided with the board as described in a later section.



## Remote-Sense Operating Mode Using PRM™ and VTM™: Non-Isolated Remote Sensing (Differential Sensing)

Mode select switch S10 setting: keep the switch S10 setting at all positions as shown in the following illustration.

**Figure 17**

Switch settings for default / adaptive-loop non-isolated remote (differential) sensing

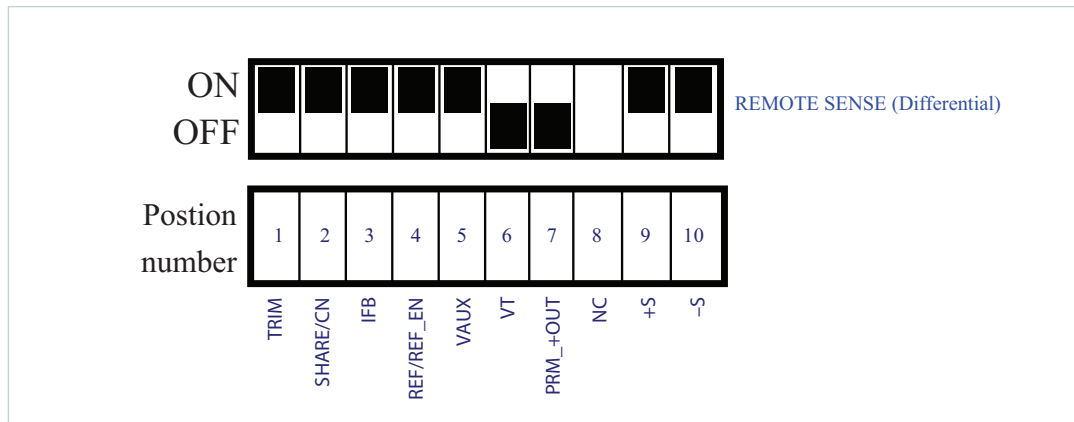

Note: To use this configuration, the VTM isolation must be broken by tying VTM –IN and VTM –OUT together.

The following table describes the switch configuration.

**Table 7**  
Switch configuration in differential sensing

Switch Position Number	ON / OFF	Connection
1	ON	TRIM pin is shorted to GND and PRM is configured for remote-sense operating mode.
2	ON	CONTROL NODE pin is connected to output of external error amplifier.
3	ON	IFB pin is connected to output of external current-sense amplifier to set the constant current limit.
4	ON	REF_EN pin is connected to input of the external voltage reference circuit to generate voltage reference for external error amplifier.
5	ON	VAUX pin is connected to power VCC of the op-amp and current-sense IC.
6	OFF	TM pin of the VTM is not connected to VT pin of the PRM.
7	OFF	PRM +OUT pin is NOT connected to local sense (single ended) of the remote-sense control circuitry.
8	either	
9	ON	VTM +OUT (+SENSE) pin is connected to positive input (+SENSE_B) of the differential buffer of remote sense control circuitry.
10	ON	VTM –OUT (–SENSE) pin is connected to negative input (–SENSE_B) of the differential buffer of remote sense control circuitry.

**Figure 18**

Remote sense: non-isolated remote-sensing (differential) control circuitry  
**BLUE** highlight = Pre-installed component  
**GREEN** highlight = user-installed component

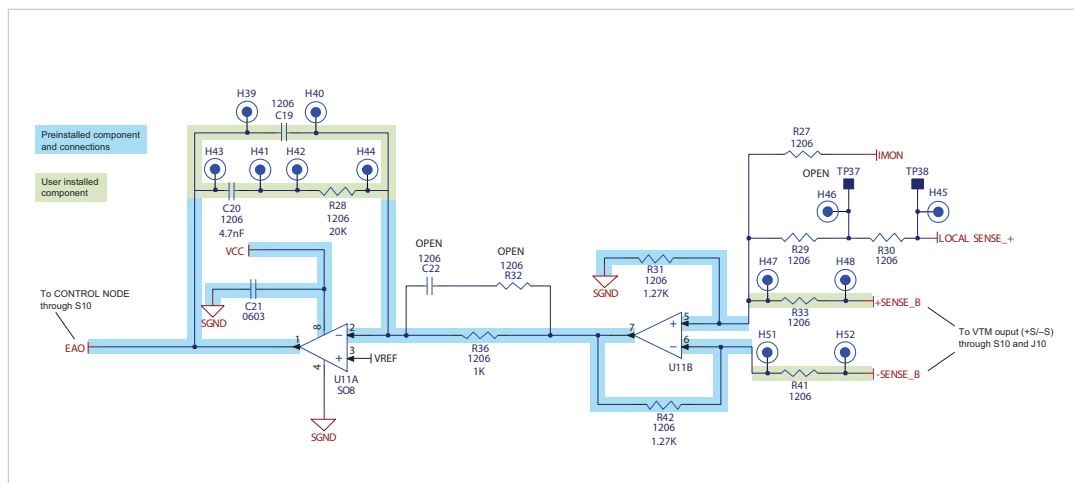

In this configuration, the PRM™ and VTM™ evaluation boards are connected together to form a PRM / VTM pair and regulation is performed at the VTM module output. The +SENSE and –SENSE connections are made at the VTM output through connector J10. This is a non-isolated configuration and therefore the VTM isolation must be broken by tying the VTM –OUT and VTM –IN pins together. The VTM evaluation board has provisions for easily breaking the isolation. U11B is configured as a differential amplifier with gain set for appropriate output voltage. R33 and R41 set the gain. POT R44 can be used to set the required voltage at the VTM output. Maximum output voltage can be set for maximum 1.25V reference voltage. R33 and R41 is calculated using following equation.

$$R_{R33} = R_{R41} = \frac{V_{OUT\_SET(MAX)} \cdot 1.27k\Omega}{1.25V} \quad (1)$$

Where:

$V_{OUT\_SET(MAX)}$  is the maximum VTM output trim voltage

Please note that R33 and R41 are not populated by default. Sockets can be used to populate through-hole resistors R33 and R41.

In order to configure the evaluation boards for non-isolated remote sense the following steps must be taken:

1. Connect the PRM and VTM evaluation boards together
2. Configure the operating mode switch as described
3. Break the isolation by connecting VTM –IN and –OUT together
4. Calculate and install the appropriate differential sense resistors (R33 and R41)
5. Install compensation components C20 and R28

### Remote-Sense Compensation Components

By default, compensation components are not populated, and are required for operation. Please note that board comes with default through-hole compensation components C20 and R28 that can be used to get a baseline for remote-sense operation. Sockets can be used for easy installation of C20 and R28. These components are not optimized and will have low bandwidth response. Transient response can be improved by adjusting the compensation components as outlined in the PRM datasheet.

It is recommended to use a network analyzer to measure the closed-loop frequency response when adjusting compensation. The PRM and VTM boards provide test points which can be used to inject the network analyzer AC signal and measure the closed-loop response.

For PRM remote-sense mode (single-ended local sense), test points TP37/TP38 and H46/H45 are in series between the PRM +OUT and the voltage-sense resistors and should be used.

For PRM-VTM remote-sense mode (differential sense) test points are provided on the VTM board in series with the +S connections (Labeled “AC Sig Inj +/-”) and should be used.

### Trim and Soft-Start Adjustment in Remote-Sense Operation

Trim and soft start adjustment in remote-sense operation is set by the reference voltage network shown below. The PRM evaluation board is normally configured for a 20 – 55V trim range. Trim POT R44 is used to trim the output voltage in remote-sense operation.

The slew rate of the output voltage during start up may be controlled by controlling the rate-of-rise of the voltage at VREF node. This can be achieved using soft-start capacitance C24. By default, C24 is populated with 0.1µF ceramic capacitance.

Sockets H55 and H56 can be used for installation of additional through-hole soft-start capacitance. It is not recommended to extend the soft start beyond 10ms.

**Figure 19**  
Voltage reference circuit

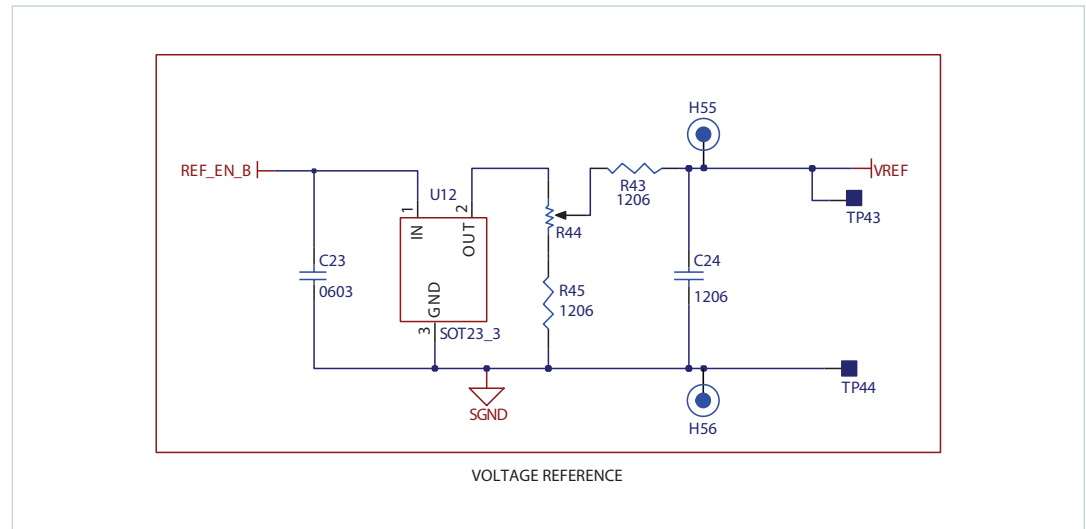

### Current Limit Adjustment in Remote-Sense Operation

In remote-sense operation, current feedback is provided externally. The current-limit set point is a function of the current sense amplifier gain, the shunt resistor and the internal current-limit threshold of PRM. Full-chip PRM evaluation board has 5mΩ current shunt whereas half-chip PRM evaluation board has 10mΩ current shunt. The IFB current-limit threshold is fixed at 2.0V. The gain of the current-sense amplifier can be changed per Equation 2 in order to adjust the current limit. Resistor R26 set the gain of the current-sense amplifier. R25 is the current shunt.

$$G_{CS} = \frac{V_{IFB\_IL}}{I_{LIMIT\_SET} \cdot R_{R25}} \quad (2)$$

By default, R26 is installed for the current limit approximately 10% above rated output current.

The current-limit set point can be changed by adjusting the value of R26 and appropriately setting the gain of the current-sense IC.

## Child Operating Mode (Arrays)

Mode select switch S10 setting: keep the switch S10 setting at all positions as shown in following illustration. Switch configuration for children is different depending on whether using Adaptive Loop or Remote Sense operating mode

**Figure 20**  
Child configuration for adaptive-loop parent. Parent/child configured PRM™ parallel arrays

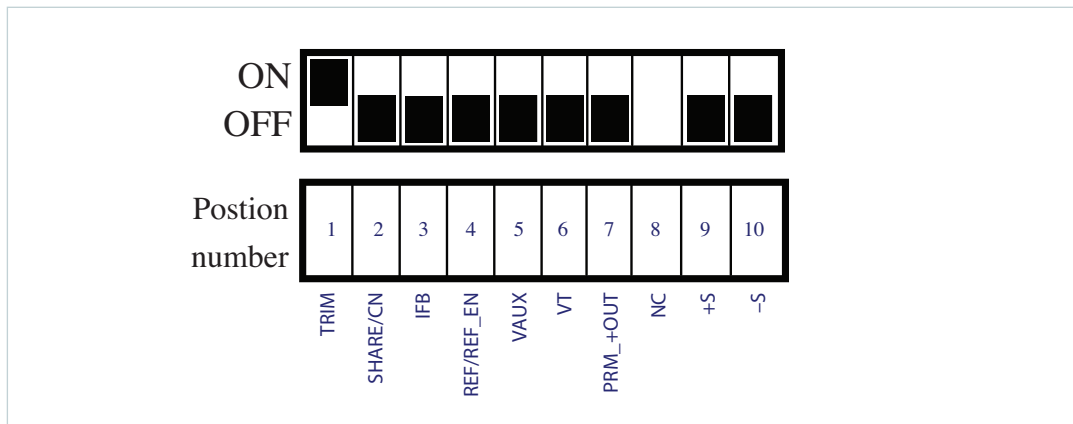

**Figure 21**  
Child configuration for remote-sense Operation. Child configured PRM parallel arrays

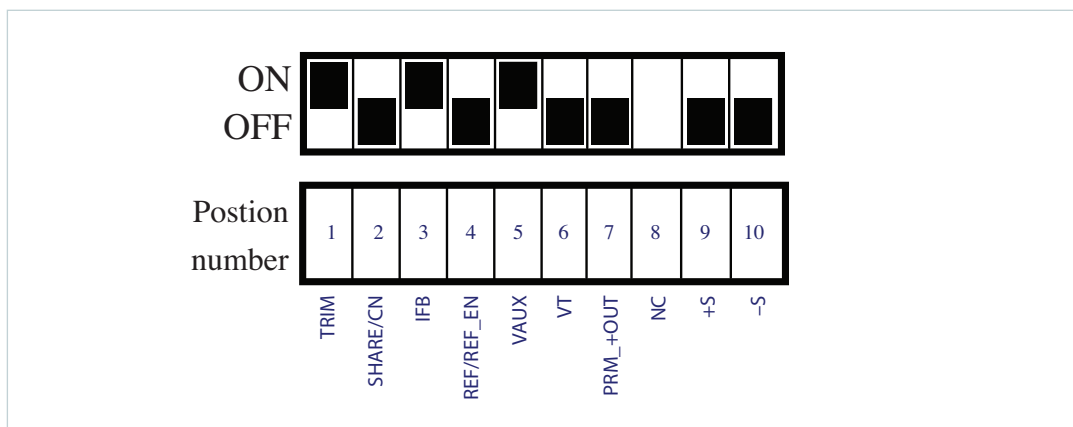

Child operation is required for constructing arrays of parallel devices as described in the next section. Switch at position 1 is ON and switch at rest of the positions are OFF. When switch at position 1 is ON, TRIM pin of the PRM is shorted to SGND and PRM is configured as a child. When a PRM is configured as child, the internal voltage and current sensing circuitry are disabled and child PRMs receive their control signal (SHARE) from a parent PRM or external remote sense circuit.

For remote-sense operation parallel array where all PRMs are configured as child, switch at position 3 should be ON to enable the constant output current limit and position 5 should be ON to power the current-sense IC and enable feedback to IFB for current limit.

## Paralleling

The paralleling and current sharing capability of the devices can be demonstrated by stacking multiple evaluation board and interconnecting the inputs and outputs with standoffs of sufficient current rating to create a parallel array. See Figure 16 below. One board should be configured normally for adaptive-loop or remote-sense operation and placed on top for easy access to control circuitry. The remaining PRMs should be configured as Children and placed underneath.

When paralleling PRMs, the ENABLE, SHARE and SGND pins should be connected together. Dual paralleling wire to board connectors (J17 and J18) are used for transferring signal pins (ENABLE, SHARE and SGND) in parallel operation from board to board. These connectors provide simple strip and insert option and accept 18-24AWG solid wires. SHARE and SGND wires can be twisted to minimize noise pick-up. Note that when using J17 and J18, SGND pins will be connected together through an on-board  $1\Omega$  series resistor to decouple signal grounds.

VTM™ boards can also be connected in parallel to create high power PRM-VTM arrays. VTM input and outputs need to be connected in parallel using same size standoffs. Each VTM requires a VC signal from a PRM in order to start and it is recommended to connect one PRM VC to one VTM VC using the connector J13 when possible. If needed a single PRM VC can be used to drive up to two VTMs (will require additional off board connections).

**Figure 22**  
Paralleling of PRM  
evaluation board

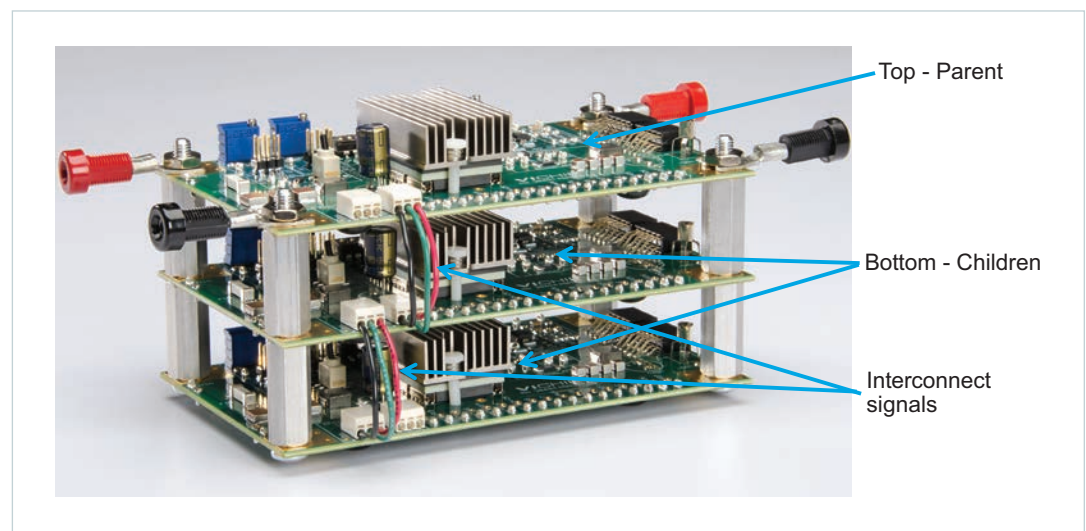

## Conclusion

The PRM™ evaluation board is a flexible tool which allows users to implement and perform basic testing on various configurations, including PRM-VTM™ module combinations. This user guide covers some basic topics; however, it cannot describe every scenario. If additional information required, please contact Vicor Applications Engineering.

---

## Limitation of Warranties

Information in this document is believed to be accurate and reliable. HOWEVER, THIS INFORMATION IS PROVIDED "AS IS" AND WITHOUT ANY WARRANTIES, EXPRESSED OR IMPLIED, AS TO THE ACCURACY OR COMPLETENESS OF SUCH INFORMATION. VICOR SHALL HAVE NO LIABILITY FOR THE CONSEQUENCES OF USE OF SUCH INFORMATION. IN NO EVENT SHALL VICOR BE LIABLE FOR ANY INDIRECT, INCIDENTAL, PUNITIVE, SPECIAL OR CONSEQUENTIAL DAMAGES (INCLUDING, WITHOUT LIMITATION, LOST PROFITS OR SAVINGS, BUSINESS INTERRUPTION, COSTS RELATED TO THE REMOVAL OR REPLACEMENT OF ANY PRODUCTS OR REWORK CHARGES).

Vicor reserves the right to make changes to information published in this document, at any time and without notice. You should verify that this document and information is current. This document supersedes and replaces all prior versions of this publication.

All guidance and content herein are for illustrative purposes only. Vicor makes no representation or warranty that the products and/or services described herein will be suitable for the specified use without further testing or modification. You are responsible for the design and operation of your applications and products using Vicor products, and Vicor accepts no liability for any assistance with applications or customer product design. It is your sole responsibility to determine whether the Vicor product is suitable and fit for your applications and products, and to implement adequate design, testing and operating safeguards for your planned application(s) and use(s).

VICOR PRODUCTS ARE NOT DESIGNED, AUTHORIZED OR WARRANTED FOR USE IN LIFE SUPPORT, LIFE-CRITICAL OR SAFETY-CRITICAL SYSTEMS OR EQUIPMENT. VICOR PRODUCTS ARE NOT CERTIFIED TO MEET ISO 13485 FOR USE IN MEDICAL EQUIPMENT NOR ISO/TS16949 FOR USE IN AUTOMOTIVE APPLICATIONS OR OTHER SIMILAR MEDICAL AND AUTOMOTIVE STANDARDS. VICOR DISCLAIMS ANY AND ALL LIABILITY FOR INCLUSION AND/OR USE OF VICOR PRODUCTS IN SUCH EQUIPMENT OR APPLICATIONS AND THEREFORE SUCH INCLUSION AND/OR USE IS AT YOUR OWN RISK.

## Terms of Sale

The purchase and sale of Vicor products is subject to the Vicor Corporation Terms and Conditions of Sale which are available at: (<http://www.vicorpower.com/termsconditionswarranty>)

## Export Control

This document as well as the item(s) described herein may be subject to export control regulations. Export may require a prior authorization from U.S. export authorities.

Contact Us: <http://www.vicorpower.com/contact-us>

**Vicor Corporation**  
25 Frontage Road  
Andover, MA, USA 01810  
Tel: 800-735-6200  
Fax: 978-475-6715  
[www.vicorpower.com](http://www.vicorpower.com)

### email

Customer Service: [custserv@vicorpower.com](mailto:custserv@vicorpower.com)  
Technical Support: [apps@vicorpower.com](mailto:apps@vicorpower.com)